

### 660,4 (26) GRDP515

GrandPro bits are designed for multiple drilling of upper well sections (surface hole, conductor hole). The use of a sealed roller bearing, optimum cutting structure and leg body protection provides excellent bit life and superior performance. Applied for drilling in soft abrasive formations.

#### SPECIFICATION

Diameter, mm (in)	660,4 (26)
IADC	515X
Seal	Double elastomer radial type
Total number of inserts/teeth (inner/outer)	247 (169/78)
Total number of rows of inserts/teeth (inner/outer)	15 (12/3)
Number and diameter of nozzles*	19,0; 3x20,6
Thread	Pin 7 5/8 Reg
Weight net/gross, kg	556 / 585,7

#### DRILLING MODES RECOMMENDED\*\*

Make-up torque, kN·m	46-54
RPM	280-40
WOB, t (lbs)	9,9-44,6 (22000-98000)

#### DESIGN FEATURES



Sealed roller bearing with two seals, rollers in large and small roller race. Provides high performance in a wide range of applications.



Chisel-shaped TCI are applied for cutting and chipping action and assure high ROP.



Double row of TCI on the cones gage are designed to increase contact area between the borehole and bit, to improve borehole quality and to protect cone body against erosion wear.



To protect leg body and prevent bit wear, shirrtail and leading edge are hardfaced.



Three side jets with additional central jet improves bottom hole cleaning, prevents cuttings re-grinding and bit balling.

#### PACKAGE DESIGN

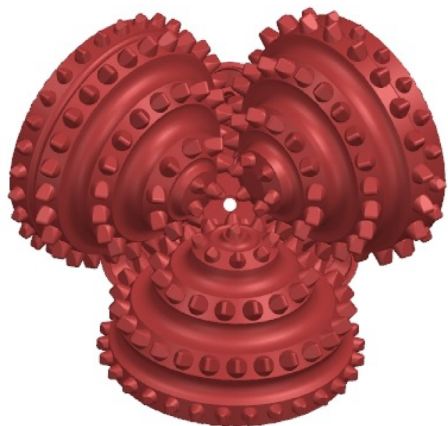
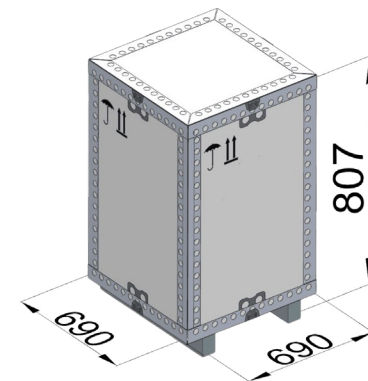

\* Standard specification may be changed on customer request.

\*\* The specified ranges of WOB and RPM represent typical drilling modes, adherence to them will not necessarily result in optimal bit life or minimum drilling costs. It is not recommended to apply both WOB and RPM upper limits at once. For the purpose of performance improvement, minor changes of the bit design may be introduced without prior customer notification.