

PRODUCT LINE TECHNPRO

139,7 (5 1/2) TCNP535K



TechnoPro bits are designed for drilling water wells, horizontal and directional drilling and construction drilling. The use of a sealed roller bearing, optimum cutting structure and leg body protection provides excellent bit life and superior performance. Applied for drilling in soft abrasive formations with medium interlayers.

SPECIFICATION

Diameter, mm (in)	139,7 (5 1/2)
IADC	535X
Seal	O-Ring
Total number of inserts/teeth (inner/outer)	110 (69/41)
Total number of rows of inserts/teeth (inner/outer)	11 (8/3)
Number and diameter of nozzles*	3x11
Thread	Pin 2 7/8 Reg
Weight net/gross, kg	11 / 11,3

PACKAGE DESIGN

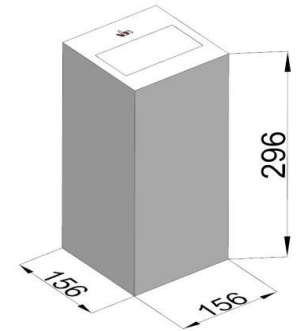

DRILLING MODES RECOMMENDED**

Make-up torque, kN·m	6,0-7,5
RPM	280-40
WOB, t (lbs)	2-9,4 (4000-21000)

DESIGN FEATURES



Sealed roller bearing with O-ring, rollers in large and small roller race. Provides high performance in a wide range of applications.



Chisel-shaped TCI are applied for cutting and chipping action and assure high ROP.



TCI on the cones gage are applied to calibrate the wellbore, protect cone body against erosion wear.



To protect leg body and prevent bit wear, shirttail and leading edge are reinforced with TCI and additionally hardfaced.



Side jet circulation is applied.

* Standard specification may be changed on customer request.

** The specified ranges of WOB and RPM represent typical drilling modes, adherence to them will not necessarily result in optimal bit life or minimum drilling costs. It is not recommended to apply both WOB and RPM upper limits at once.

For the purpose of performance improvement, minor changes of the bit design may be introduced without prior customer notification.